

Flare T-joint 60/60/60 type 6132116-SS

Stock codes A-0003211 and B04210

TECHNICAL DATA SHEET TB3400 REVISION B DATE OF ISSUE 09 Jul 2014

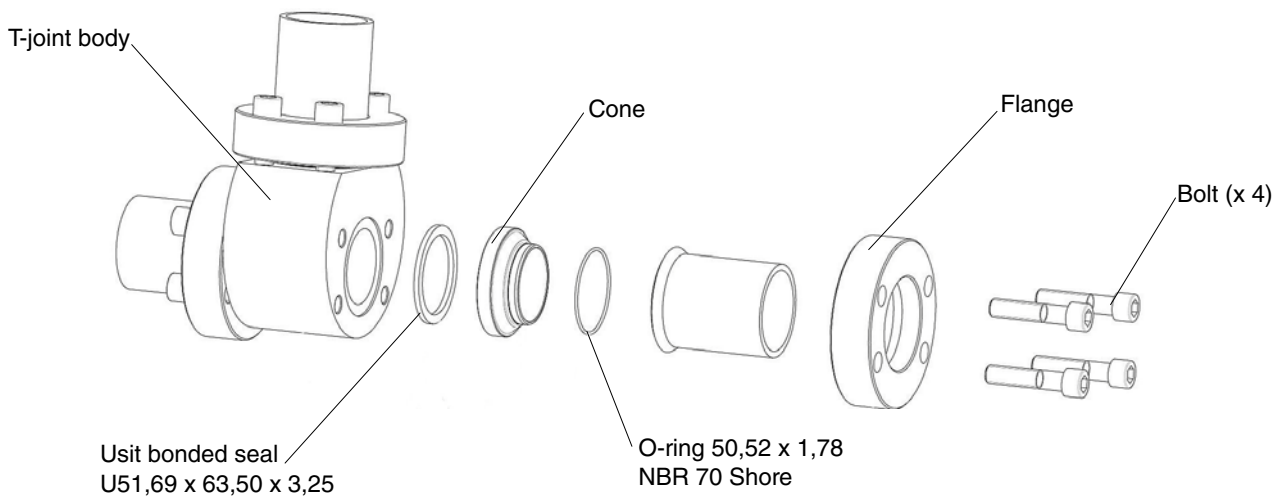
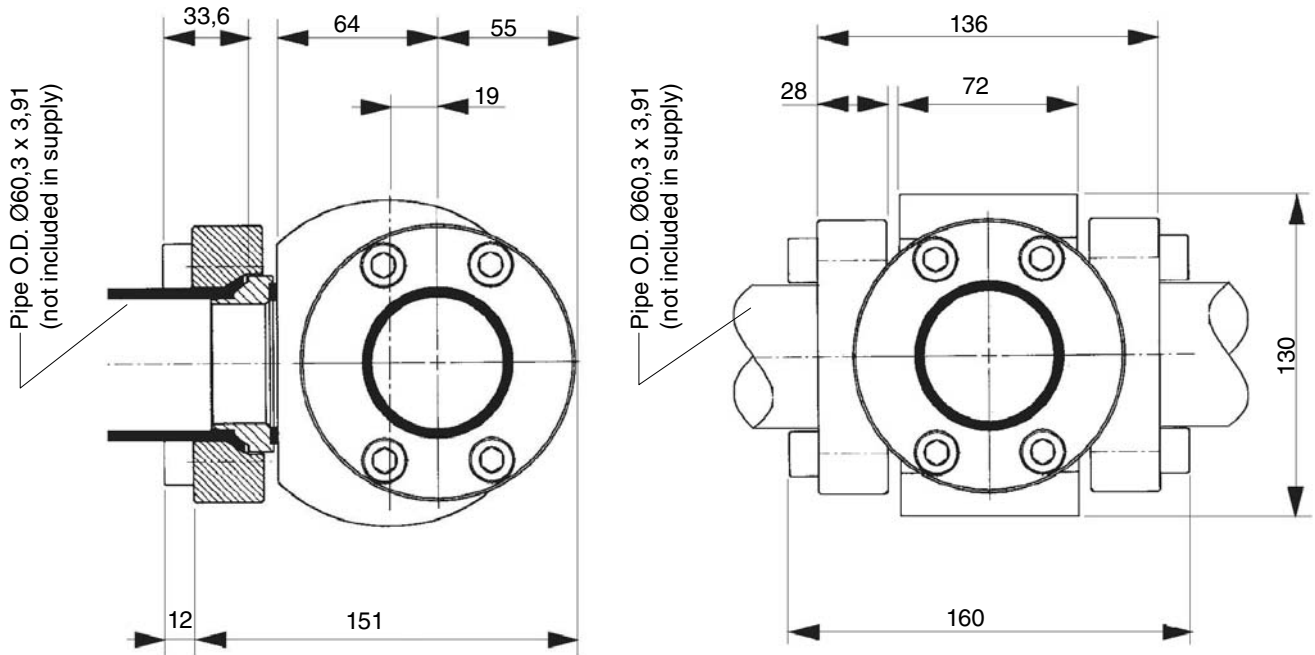

Flare T-joint 60/60/60 type 6132116-SS

Pipe moulding instruction

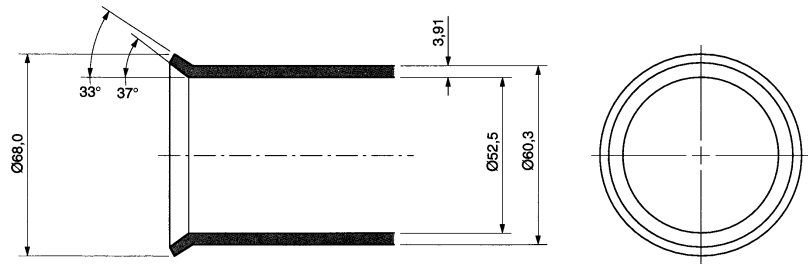

Stock code	A-0003211	B04210
Joint body	Stainless steel (EN 1.4404 / AISI 316L)	Stainless steel (EN 1.4305 / AISI 303)
Flanges	Steel, Zn finishing	Steel, Zn finishing
Usit	AISI 316	Steel, Zn finishing
Cones	EN 1.4404 / AISI 316L	Brass
Bolts	Steel, Zn finishing	Steel, Zn finishing

General	Max. working pressure	140 bar
----------------	-----------------------	---------